

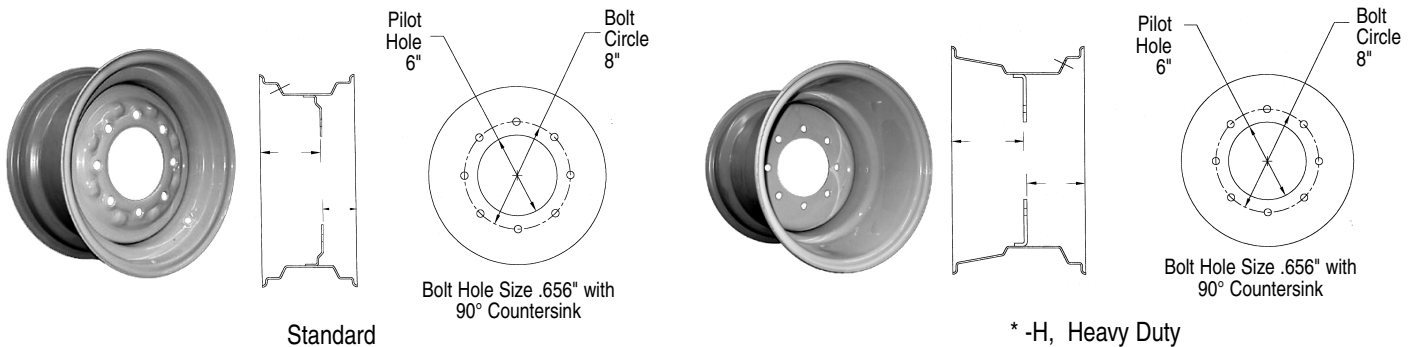

SMALL DIAMETER WHEELS

Implement Wheels

8 Hole Ag



Wheel Size	Code	Offset	V/S	OPP V/S	Cap	Color	New Wold Part Number	Wt.
5X15	IW515-8-470-V	- 2 7/16"	5/8"	4 3/4"	3200	O	WNIW150050-088I9-047OR-V	25
6X15	IW615-8-520-V	+ 2 3/16"	1"	5 1/4"	3800	O	WNIW150060-088I9-052OR-V	28
8X15	IW815-8-56W	+ 1 1/8"	3"	5 5/8"	5700	W	WNIW150080-088I9-056OW	30
10X15	IW1015-8-35W	+ 1 1/2"	6 7/8"	3 1/2"	5000	W	WNIW150100-088I9-035OW	33
10X15	IW1015-8-66W	+ 1 1/8"	3 7/8"	6 5/8"	5700	W	WNIW150100-088I9-066OW	33
10X15	IW1015-8-47W	-3/4"	5 3/4"	4 3/4"	5700	W	WNIW150100-088I9-047OW	33
13X15	IW1315-8-81W	+ 1 1/8"	5 1/4"	8 1/8"	500	W	WNIW150130-088I9-081OW	37
6X16	IW616-8-45W	+ 1 1/8"	2"	4 1/2"	5700	W	WNIW160060-088I9-045OW	30
8X16	IW816-8-13W	- 3 1/8"	7 1/8"	1 3/8"	5500	W	WNIW160080-088I9-014OW	37
8X16	IW816-8-48Y	+ 1/4"	3 3/4"	4 7/8"	5500	Y	WNIW160080-088I9-048JY	37
8X16	IW816-8-56W	+ 1 1/8"	3"	5 5/8"	5500	W	WNIW160080-088I9-056OW	37
8X16	IW816-8-27W	- 1 11/16"	5 7/8"	2 3/4"	5500	W	WNIW160080-088I9-058OW	37
10X16	IW1016-8-27W	- 2 13/16"	8"	2 3/4"	6000	W	WNIW160100-088I9-027OW	43
10X16	IW1016-8-47Y	- 3/4"	5 3/4"	4 3/4"	6000	Y	WNIW160100-088I9-047JY	43
10X16	IW1016-8-60W	+ 3/8"	4 5/8"	6"	6000	W	WNIW160100-088I9-060OW	43
10X16	IW1016-8-66W	+ 1 1/8"	4"	6 5/8"	5500	W	WNIW160100-088I9-066OW	43
11X16.1	IW11161-8-45Y	- 1 1/2"	7"	4 1/2"	5500	Y	WNIW161110-088I9-045JY	44
11X16.1	IW11161-8-45W	- 1 1/2"	7"	4 1/2"	5500	W	WNIW161110-088I9-045OW	44
11X16.1	IW11161-8-63W	+ 3/8"	5 1/4"	6 3/8"	6000	W	WNIW161110-088I9-063OW	44
11X16.1	IW11161-8-72W	+ 1 1/8"	4 1/4"	7 1/4"	6000	W	WNIW161110-088I9-072OW	44
14X16.1	IW14161-8-41W	- 3 1/2"	10 5/8"	4 1/8"	8000	W	WNIW161140-088I9-041OW-H	60
14X16.1	IW14161-8-55W-H	- 2"	9 3/8"	5 1/2"	8000	W	WNIW161140-088I9-055OW-H	60
14X16.1	IW14161-8-62W	+ 1 1/16"	8 1/2"	6 1/4"	6000	W	WNIW161140-088I9-062OW	53
14X16.1	IW14161-8-80W-H	+ 3/8"	6 3/4"	8"	8000	W	WNIW161140-088I9-080OW-H	60
14X16.1	IW14161-8-87W-H	+ 1 1/8"	6 1/8"	8 3/4"	8000	W	WNIW161140-088I9-087OW-H	60
16X16.1	IW16161-8-37W-H	- 4 3/4"	12 7/8"	3 3/4"	8000	W	WNIW161160-088I9-037OW-H	62
16X16.1	IW16161-8-70W-H	- 1 13/16"	9 3/4"	7"	8000	W	WNIW161160-088I9-070OW-H	62
16X16.1	IW16161-8-88W-H	+ 3/8"	7 3/4"	8 7/8"	8000	W	WNIW161160-088I9-089OW-H	62
16X16.1	IW16161-8-97W	+ 1 1/8"	7"	9 3/4"	8000	W	WNIW161160-088I9-097OW	55
16X16.1	IW16161-8-97W-H	+ 1 1/8"	7"	9 3/4"	8000	W	WNIW161160-088I9-097OW-H	62
18X16.1	IW18161-8-98W-H	+ 3/8"	8 3/4"	9 7/8"	8000	W	WNIW161180-088I9-098OW-H	70

Prices are effective

Prices are subject to change without notice

Prices are F.O.B. St. Ansgar, Iowa

P.O. Box 129 • St. Ansgar, Iowa 50472 • 614-713-2205 • 1-800-443-9653 • Fax 641-713-4483



SMALL DIAMETER WHEELS

Implement Wheels

8 Hole Ag cont.

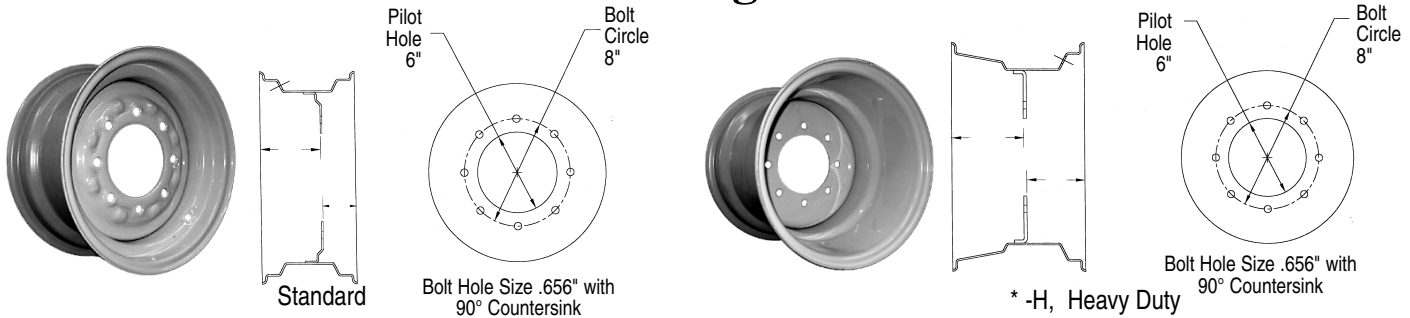

Wheel Size	Code	Offset	V/S	OPP V/S	Cap	Color	New Wold Part Number	Wt.
18X16.1	IW18161-8-105W-H	+ 1 1/8"	7 3/4"	10 1/2"	8000	W	WNIW161180-088I9-105OW-H	70
8.25X16.5	IW825165-8-50Y-V	+ 3/8"	4"	5"	6000	Y	WNIW165082-088I9-050IY-V	38
8.25X16.5	IW825165-8-50O-V	+ 3/8"	4"	5"	6000	O	WNIW165082-088I9-050OR-V	38
8.25X16.5	IW825165-8-57W	+ 1 1/8"	3 1/2"	5 3/4"	6000	W	WNIW165082-088I9-057OW	38
9.75X16.5	IW975165-8-35Y-V	- 1 15/16"	7 1/8"	3 1/2"	6000	IY	WNIW165097-088I9-035IY-V	40
9.75X16.5	IW975165-8-60W	+ 3/8"	4 7/8"	6"	6000	W	WNIW165097-088I9-060OW	40
9.75X16.5	IW975165-8-67Y-V	+ 1 1/8"	4"	6 3/4"	6000	IY	WNIW165097-088I9-067IY-V	40
10.5X17.5	IW105175-8-50O	- 1"	5"	6 1/2"	6000	IY	WNIW-175105-088I9H-050OR	55
5.5X18	IW5518-8-25W	- 3/4"	3 3/4"	2 1/2"	3300	W	WNIW180055-088I9-025OW	33
5.5X20	IW5520-8-18W	- 1 1/2"	4 3/4"	1 7/8"	3400	W	WNIW200055-088I9-018OW	34
7X20	IW720-8-40W	- 1 1/2"	3 3/4"	4"	3400	W	WNIW200070-088I9-040OW	35
8X20	IW820-8-37WTS	+ 1 1/8"	5 3/4"	3 1/8"	6000	W	WNIW200080-088I9-037OW	50
8X20	IW820-8-62WIS	+ 1 1/8"	3"	6"	6000	W	WNIW200080-088I9-062OW	50
8.25X22.5	IW825225-8-32W	- 1 1/2"	6"	3 1/4"	6000	W	WNIW225082-088I9-032OW	58
11.25X22.5	IW1125225-8-52W	- 1 1/8"	7 1/8"	5 1/4"	6000	W	WNIW225112-088I9-052OW	65
11.25X22.5	IW1125225-8-68W	+ 3/8"	5 1/2"	6 7/8"	6000	W	WNIW225112-088I9-068OW	65
13.5X22.5	IW135225-8-65W-H	- 1"	8"	6 1/2"	8000	W	WNIW225135-088I9-065OW-H	90
13.5X22.5	IW135225-8-77W-H	+ 9/32"	6 3/4"	7 3/4"	8000	W	WNIW225135-088I9-077OW-H	90
8.25X24.5	IW825245-8-32W	- 1 1/2"	6"	3 1/4"	6000	W	WNIW245082-088I9-032OW	75

Prices are effective

Prices are subject to change without notice

Prices are F.O.B. St. Ansgar, Iowa

P.O. Box 129 • St. Ansgar, Iowa 50472 • 614-713-2205 • 1-800-443-9653 • Fax 641-713-4483



SMALL DIAMETER WHEELS

Implement Wheels

8 Hole Ag

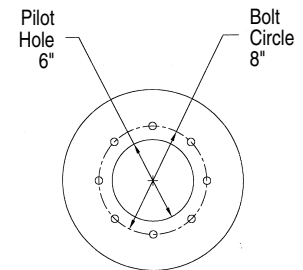
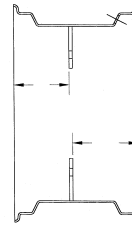

Bolt Hole Size .656" with 90° Countersink

Wheel Size	Code	Offset	V/S	OPP V/S	Cap	Color	New Wold Part Number	Wt.
8.25X22.5	PW825225-8-32W	- 1 1/2"	5 1/2"	3 1/4"	PLATE	W	WPPW-225082-Q08819-032CW	65
11.25X22.5	PW1125225-8-35W	- 4"	8 3/4"	3 1/2"	PLATE	W	WPPW-225112-Q08819-035CW	75
13X22.5	PW13225-8-62W	- 1"	7 7/8"	6 1/4"	PLATE	W	WPPW-225130-Q08819-062CW	105
13X22.5	PW13225-8-45W	- 2 3/4"	9 5/8"	4 1/2"	PLATE	W	WPPW-225130-Q08819-045CW	105
8.25X24.5	PW825245-8-32W	- 1 1/2"	5 1/2"	3 1/4"	PLATE	W	WPPW-245082-Q08819-032CW	85

8 Hole JD

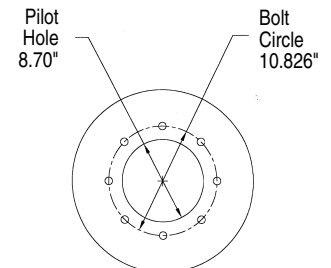
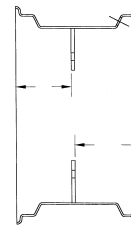

Bolt Hole Size .81" with No Countersink

Wheel Size	Code	Offset	V/S	OPP V/S	Cap	Color	New Wold Part Number	Wt.
18X16.1	PW18161-8JD-95W	0"	9 1/4"	9 1/2"	PLATE	W	WPPW-161180-Q08AMF-095CW	60
13X22.5	PW13225-8JD-62W	- 1 "	7 7/8"	6 1/4"	PLATE	W	WPPW-225130-Q08AMF-062CW	105

10 Hole 13/16" Straight Hole

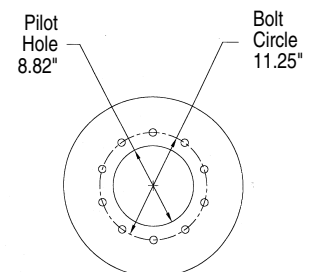
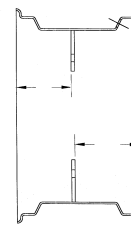

Bolt Hole Size .81" with No Countersink

Wheel Size	Code	Offset	V/S	OPP V/S	Cap	Color	New Wold Part Number	Wt.
18X16.1	PW18161-10BS-95W	0"	9 1/4"	9 1/2"	PLATE	W	WPPW-161180-Q10BMF1-095CW	60
13X22.5	PW13225-10BS-62W	- 1 "	7 7/8"	6 1/4"	PLATE	W	WPPW-225130-Q10BMF1-062CW	105

Prices are effective

Prices are subject to change without notice

Prices are F.O.B. St. Ansgar, Iowa

P.O. Box 129 • St. Ansgar, Iowa 50472 • 614-713-2205 • 1-800-443-9653 • Fax 641-713-4483